

Pneumatic Actuator Application Sheet

Distributor: _____

End-User: _____

Salesperson: _____

Phone: _____

Fax: _____

Stroke: _____ Time to make move: _____ Load: _____ Incline: _____

Check if load is externally supported

Actuator type:

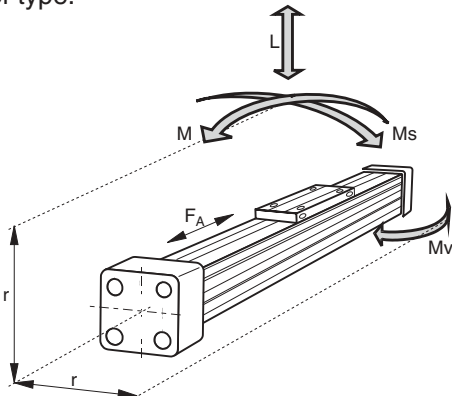

M = _____

MS = _____

MV = _____

Description: _____

See Attached for additional information

Special Features Required:

Switches Type _____ Qty. _____

Please complete and fax to: 630/871-1515, Attention: Technical Support